

# evolve

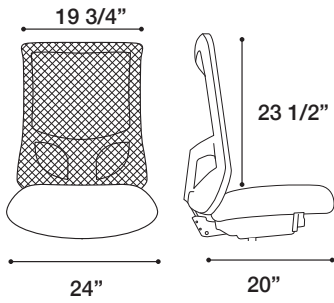

**MANAGERS HIGH BACK BT15 AND BT16**



## MESH OPTIONS



**WHITE (M01)**

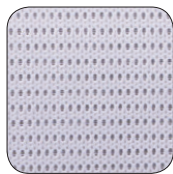

**SILVER (M02)**



**CHARCOAL (M03)**

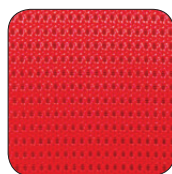

**RED (M04)**

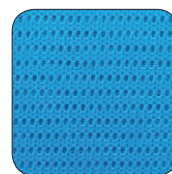

**AZURE/BLUE (M05)**

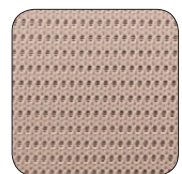

**CAPPUCINO/TAN (M06)**

# evolve

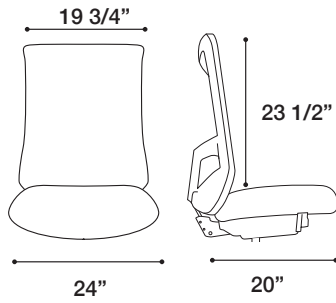

**MANAGERS HIGH BACK BT17 AND BT18**



## FEATURES & BENEFITS

- » Comfortably accommodates up to 400 lbs.
- » Heavy-duty base and casters
- » Meets CAL 117-2013
- » Standard adjustable ratcheting back
- » 7 Mesh color options